



10Gbps 80km  
XFP DWDM Optical Transceiver

## OP-MDCX8xxL1SD-80

### Product Features

- Duplex LC Connector
- Support hot-pluggable
- Metal with lower EMI
- Excellent ESD protection
- XFP MSA compliant
- RoHS Compliant and Lead-Free
- Compliant with IEEE 802.3ae
- ITU-T G.959,G.691 and G.692 compliant
- Temperature-stabilized DWDM-rated EML transmitter and APD ROSA
- Up to 80KM for single mode fiber
- GR-253-CORE compliant
- +5.0V and +3.3V power supply and power dissipation <3.5W

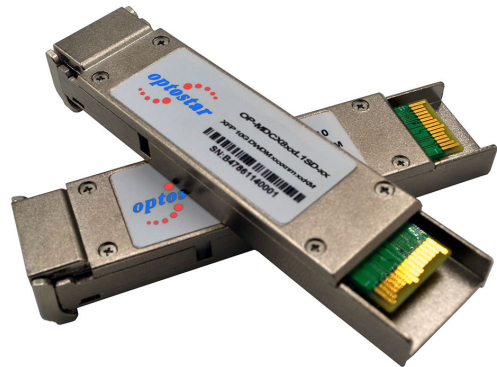

### Applications

- 10GBASE-ER/EW 10G Ethernet
- 10G Fibre Channel
- SONET OC-192 /SDH STM-64
- DWDM Networks
- SONET OC-192 /SDH STM-64
- Optical interface with optical amplifier
- Other Optical Link

### General

OPTOSTAR's OP-MDCX8xxL1SD-80 10G Cooled EML XFP DWDM transceivers are designed for 10G Ethernet 10G BASE-ZR/ZW per 802.3ae and 10G SONET OC-192/SDH STM-64, and it can support data-rate from 9.953Gb/s to 11.3Gb/s. Digital diagnostics are available via I2C interface as specified in the XFP MSA.

The transceiver designs are optimized for high performance and cost effective to supply customers the best solutions for datacom and telecom applications.

Product Selection			
Product Code	ITU channel	Frequency (THz)	Center Wavelength (nm)
OP-MDCX861L1SD-80	61	196.1	1528.77
OP-MDCX860L1SD-80	60	196.0	1529.55
OP-MDCX859L1SD-80	59	195.9	1530.33
OP-MDCX858L1SD-80	58	195.8	1531.12
OP-MDCX857L1SD-80	57	195.7	1531.90
OP-MDCX856L1SD-80	56	195.6	1532.68
OP-MDCX855L1SD-80	55	195.5	1533.47
OP-MDCX854L1SD-80	54	195.4	1534.25
OP-MDCX853L1SD-80	53	195.3	1535.04
OP-MDCX852L1SD-80	52	195.2	1535.82
OP-MDCX851L1SD-80	51	195.1	1536.61
OP-MDCX850L1SD-80	50	195.0	1537.40
OP-MDCX849L1SD-80	49	194.9	1538.19
OP-MDCX848L1SD-80	48	194.8	1538.98
OP-MDCX847L1SD-80	47	194.7	1539.77
OP-MDCX846L1SD-80	46	194.6	1540.56
OP-MDCX845L1SD-80	45	194.5	1541.35
OP-MDCX844L1SD-80	44	194.4	1542.14
OP-MDCX843L1SD-80	43	194.3	1542.94
OP-MDCX842L1SD-80	42	194.2	1543.73
OP-MDCX841L1SD-80	41	194.1	1544.53
OP-MDCX840L1SD-80	40	194.0	1545.32
OP-MDCX839L1SD-80	39	193.9	1546.12
OP-MDCX838L1SD-80	38	193.8	1546.92
OP-MDCX837L1SD-80	37	193.7	1547.72
OP-MDCX836L1SD-80	36	193.6	1548.51
OP-MDCX835L1SD-80	35	193.5	1549.32
OP-MDCX834L1SD-80	34	193.4	1550.12
OP-MDCX833L1SD-80	33	193.3	1550.92
OP-MDCX832L1SD-80	32	193.2	1551.72
OP-MDCX831L1SD-80	31	193.1	1552.52
OP-MDCX830L1SD-80	30	193.0	1553.33
OP-MDCX829L1SD-80	29	192.9	1554.13
OP-MDCX828L1SD-80	28	192.8	1554.94
OP-MDCX827L1SD-80	27	192.7	1555.75
OP-MDCX826L1SD-80	26	192.6	1556.55
OP-MDCX825L1SD-80	25	192.5	1557.36
OP-MDCX824L1SD-80	24	192.4	1558.17
OP-MDCX823L1SD-80	23	192.3	1558.98
OP-MDCX822L1SD-80	22	192.2	1559.79
OP-MDCX821L1SD-80	21	192.1	1560.61
OP-MDCX820L1SD-80	20	192.0	1561.42
OP-MDCX819L1SD-80	19	191.9	1562.23
OP-MDCX818L1SD-80	18	191.8	1563.05
OP-MDCX817L1SD-80	17	191.7	1563.86

## Regulatory Compliance

- ESD to the Electrical PINs: compatible with MIL-STD-883E Method 3015.7
- ESD to the Duplex LC Receptacle: compatible with IEC 61000-4-2
- Immunity compatible with IEC 61000-4-3
- EMI compatible with FCC Part 15 Class B EN55022 Class B (CISPR 22B) VCCI Class B
- Laser Eye Safety compatible with FDA 21CFR 1040.10 and 1040.11 EN60950, EN (IEC) 60825-1,2
- RoHs compliant with 2002/95/EC 4.1&4.2 2005/747/EC

## Pin Descriptions

Pin	Symbol	Name/Description	Ref.
1	GND	Module Ground	
2	VEE5	(Not required)	
3	MOD_DESEL	Module De-select; When held low allows the module to respond to 2-wire serial interface. LVTTTL-I	
4	/INTERRUPT	Interrupt; Indicates presence of an important condition which can be read via the 2-wire serial interface. LVTTTL-O	2
5	TX_DIS	Transmitter Disable. Logic1 indicates laser output disabled, LVTTTL-I	
6	VCC5	+5V Power Supply	
7	GND	Module Ground	1
8	VCC3	+3.3V Power Supply	
9	VCC3	+3.3V Power Supply	
10	SCL	2-Wire Serial Interface Clock. LVTTTL-I	2
11	SDA	2-Wire Serial Interface Data Line. LVTTTL-I/O	2
12	MOD_Abs	Indicates Module is not present. Grounded in the Module. LVTTTL-O	2
13	MOD_NR	Module Not Ready; Indicating Module Operational Fault. Open-collector. LVTTTL-O	2
14	RX_LOS	Loss of Signal indication. Logic 1 indicates loss of Signal. Open-collector. LVTTTL-O	2
15	GND	Module Ground	1
16	GND	Module Ground	1
17	RD-	Receiver Inverted Data Output. CML-O	
18	RD+	Receiver Non-Inverted Data Output. CML-O	
19	GND	Module Ground	1
20	VCC2	+1.8V Power Supply (Not required).	3
21	P_DOWN/RST	Power down; When high, requires the module to limit power consumption to 1.5W or below. 2-Wire serial interface must be functional in the low power mode. LVTTTL-I Reset; The falling edge initiates a complete reset of the module including the 2-wire serial interface, equivalent to a power cycle. LVTTTL-I	
22	VCC2	+1.8V Power Supply (Not required)	3
23	GND	Module Ground	1
24	REFCLK+	Reference Clock (Not required)	
25	REFCLK-	Reference Clock (Not required)	
26	GND	Module Ground	1
27	GND	Module Ground	1
28	TD-	Transmitter Inverted Data Input. CML-I	
29	TD+	Transmitter Non-Inverted Data Input. CML-I	
30	GND	Module Ground	1

**Notes:**

1. Module ground pins GND are isolated from the module case and chassis ground within the module.
2. Open collector; Should be pulled up with 4.7K-10Kohms to a voltage between 3.15V and 3.6V on the host board.
3. The pins are open within module.

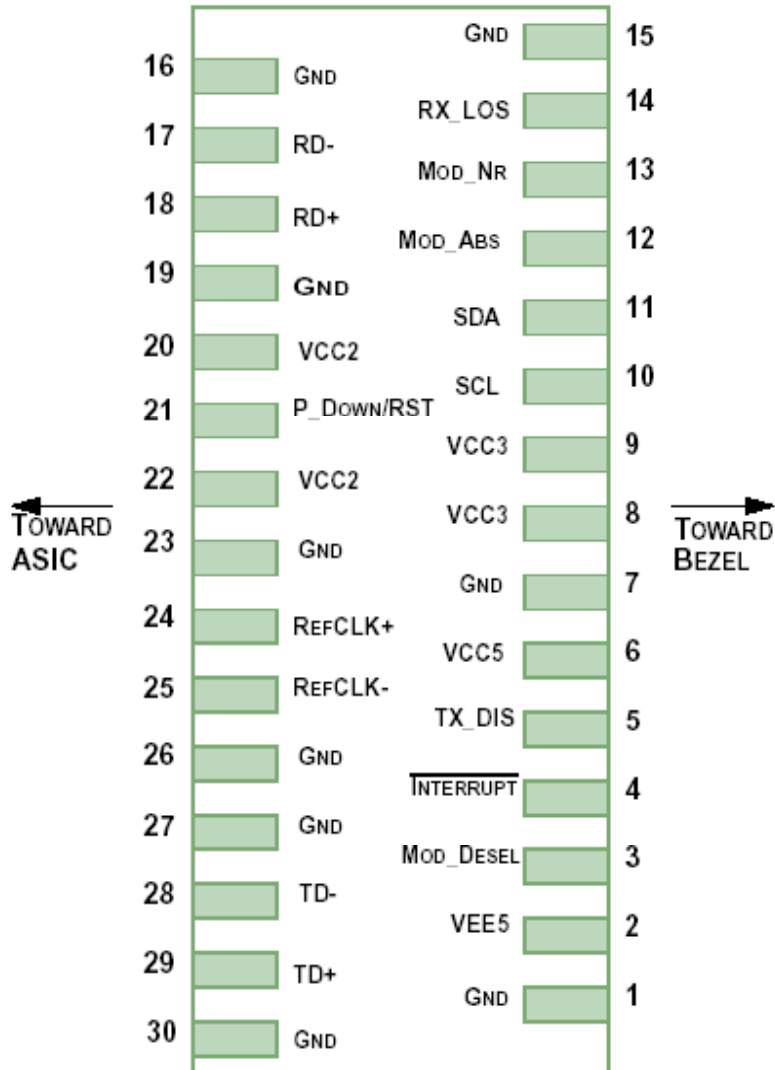

**Pin-out of Connector Block on Host Board**

### Typical Interface Circuit

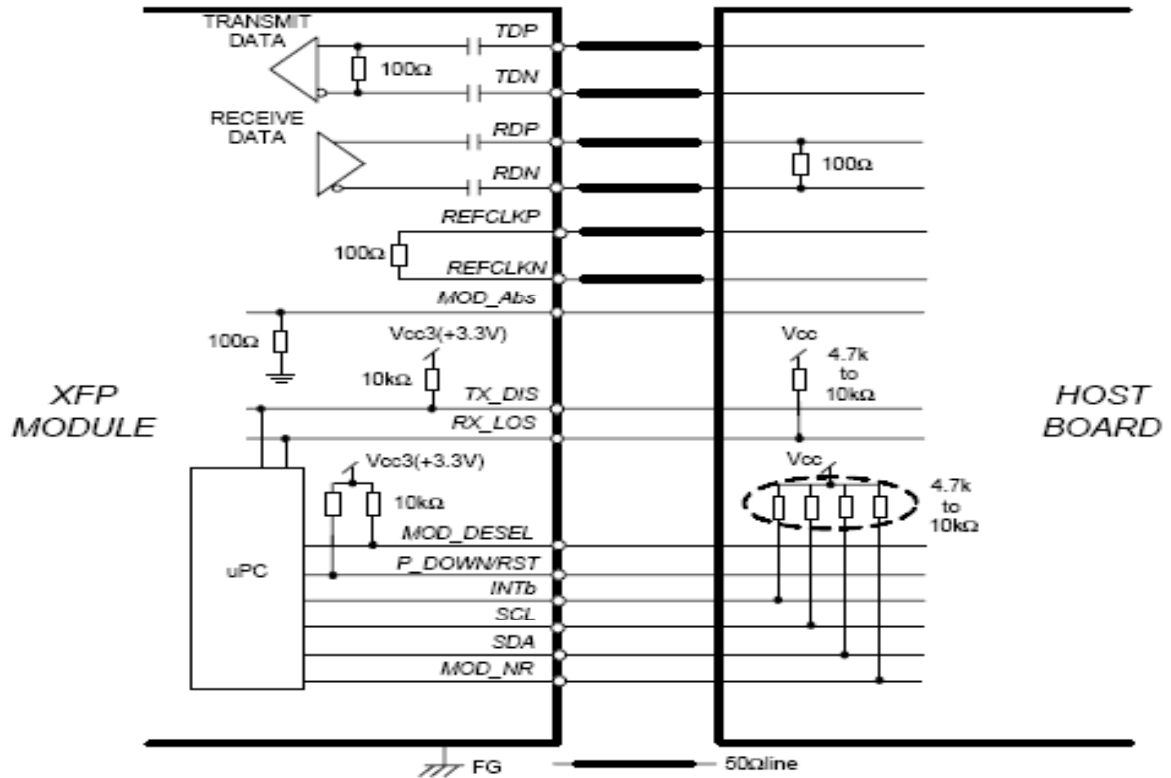

### Absolute Maximum Ratings

Parameter	Symbol	Min	Typ	Max	Unit	Ref.
Maximum Supply Voltage	Vcc3	-0.5		+4.0	V	
	Vcc5	-0.5		6.0	V	
Storage Temperature	TS	-40		+85	°C	
Operating Humidity	RH	5		85	%	

**Recommended Operating Conditions**

Parameter	Symbol	Min	Typ	Max	Unit	Ref.
Power Supply Voltage	Vcc3	3.13	3.30	3.47	V	
	Vcc5	4.75	5.0	5.25	V	
Power Supply Current	Icc3	-	-	750	mA	1
	Icc5	-	-	500	mA	
Case Operating Temperature	Tc	0	-	+70	°C	
9/125um G.652 SMF	Lmax	-	-	80	km	

**Electrical Characteristics (TOP=25°C, Vcc=3.3Volts)**

Parameter	Symbol	Min	Typ	Max	Unit	Ref.
<b>Transmitter</b>						
Differential data input swing	Vin,pp	120	600	850	mV	
Input differential impedance	Zin	90	100	110	Ω	
<b>Receiver</b>						
Differential data output swing	Vout, pp	300	600	850	mV	
Output Differential Impedance	Zin	90	100	110	Ω	
<b>Transceiver</b>						
Ref-clk input swing	Ref,pp	400		2400	mV	
TX Disable-High	-	2.0		Vcc+0.3	V	
TX Disable-Low	-	Vee-0.3		0.8	V	
LOS-High	-	2.0		Vcc+0.3	V	
LOS-Low	-	Vee-0.3		0.8	V	
MOD_DESEL-High	-	2.0	-	Vcc+0.3	V	
MOD_DESEL-Low	-	Vee-0.3	-	0.8	V	
MOD_INT-High	-	2.0	-	Vcc+0.3	V	
MOD_INT-Low	-	Vee-0.3	-	0.8	V	
MOD_NR-High	-	2.0	-	Vcc+0.3	V	
MOD_NR-Low	-	Vee-0.3	-	0.8	V	
P_DOWN/RST-High	-	2.0	-	Vcc+0.3	V	
P_DOWN/RST-Low	-	Vee-0.3	-	0.8	V	

**Notes:**

1. Maximum total power value is specified across the full temperature and voltage range and the inrush current is included

**Optical Characteristics (TOP=25°C, Vcc=3.3 Volts)**

Parameter	Symbol	Min	Typ	Max	Unit	Ref.
<b>Transmitter</b>						
Operating Data Rate		9.95		11.3		
Output Opt. Power	PO	-1	-	3	dBm	
Center Wavelength Spacing			100		GHZ	3
Center Wavelength (BOL)	$\lambda$	X-0.025	X	X+0.025	nm	3
Center Wavelength (EOL)	$\lambda$	X-0.1	X	X+0.1	nm	3
Side Mode Suppression Ratio	SMSR	30	-	-	dB	
Optical Extinction Ratio	ER	9	-	-	dB	
Dispersion penalty(@1450ps/nm, non-FEC rate)				2	dB	4
Dispersion penalty(@1300ps/nm, FEC rate)				3		4
Generation Jitter 1(20KHZ-80MHZ)				0.3	Ulp-p	1
Generation Jitter 2(4MHZ-80MHZ)				0.1	Ulp-p	1
Optical Eye Mask 1		ITU-T G.691				1
Optical Eye Mask 2		IEEE802.3ae				2
<b>Receiver</b>						
Overload	Po	-8	-	-	dBm	
Optical Center Wavelength	$\lambda_C$	1270	-	1600	nm	
LOS De-Assert	LOSD	-	-	-26	dBm	
LOS Assert	LOSA	-34	-	-	dBm	
LOS Hysteresis	-	0.5	-	5	dB	
Receiver Sensitivity @non-FEC rate	Pmin1			-24	dBm	4
Receiver Sensitivity @ FEC rate	Pmin2			-27	dBm	4
Require OSNR @ FEC rate	OSNR1	16			dB	4,5
Require OSNR @ non-FEC rate	OSNR2	24			dB	4,5
OSNR penalty(@1450ps/nm, non-FEC rate)				4	dB	5
OSNR penalty(@1300ps/nm, FEC rate)				4	dB	5

**Notes:**

1. Measured at 9.95328Gb/s , PRBS2<sup>31</sup>-1,NRZ,
2. Measured at 10.3125Gb/s, Non-framed PRBS2<sup>31</sup>-1, NRZ
3. X=Specified ITU Grid Wavelength
4. non-FEC rate refers 9.9/10.3/10.5Gbps, and FEC rate refers 10.7/11.1/11.3Gbps, BER of 1E-12 for non-FEC rate, and 1E-4 for FEC rate
- 5, at Received Power:-7 to -18dBm

## Management Interface

XFP 2-wire serial interface is specified in the Chapter 4 of the XFP MSA specification. The XFP 2-wire serial interface is used for serial ID, digital diagnostics, and certain control functions. The 2-wire serial interface is mandatory for all XFP modules. The 2-wire serial interface address of the XFP module is 1010000X(A0h). In order to access to multiple modules on the same 2-wire serial bus, the XFP has a MOD\_DESEL(module deselect pin). This pin (which is pull high or deselected in the module) must be held low by the host to select of interest and allow communication over 2-wire serial interface. The module must not respond to or accept 2-wire serial bus instructions unless it is selected.

## XFP Management Interface

XFP Management interface is specified in the Chapter 5 of the XFP MSA specification. The Figure 1 shows the structure of the memory map. The normal 256 Byte address space is divided into lower and upper blocks of 128 Bytes. The lower block of 128 Byte is always directly available and is used for the diagnostics and control functions that must be accessed repeatedly. Multiple blocks of memories are available in the upper 128 Bytes of the address space. These are individually addressed through a table select Byte which the user enters into a location in the lower address space. The upper address space tables are used for less frequently accessed functions and control space for future standards definition.

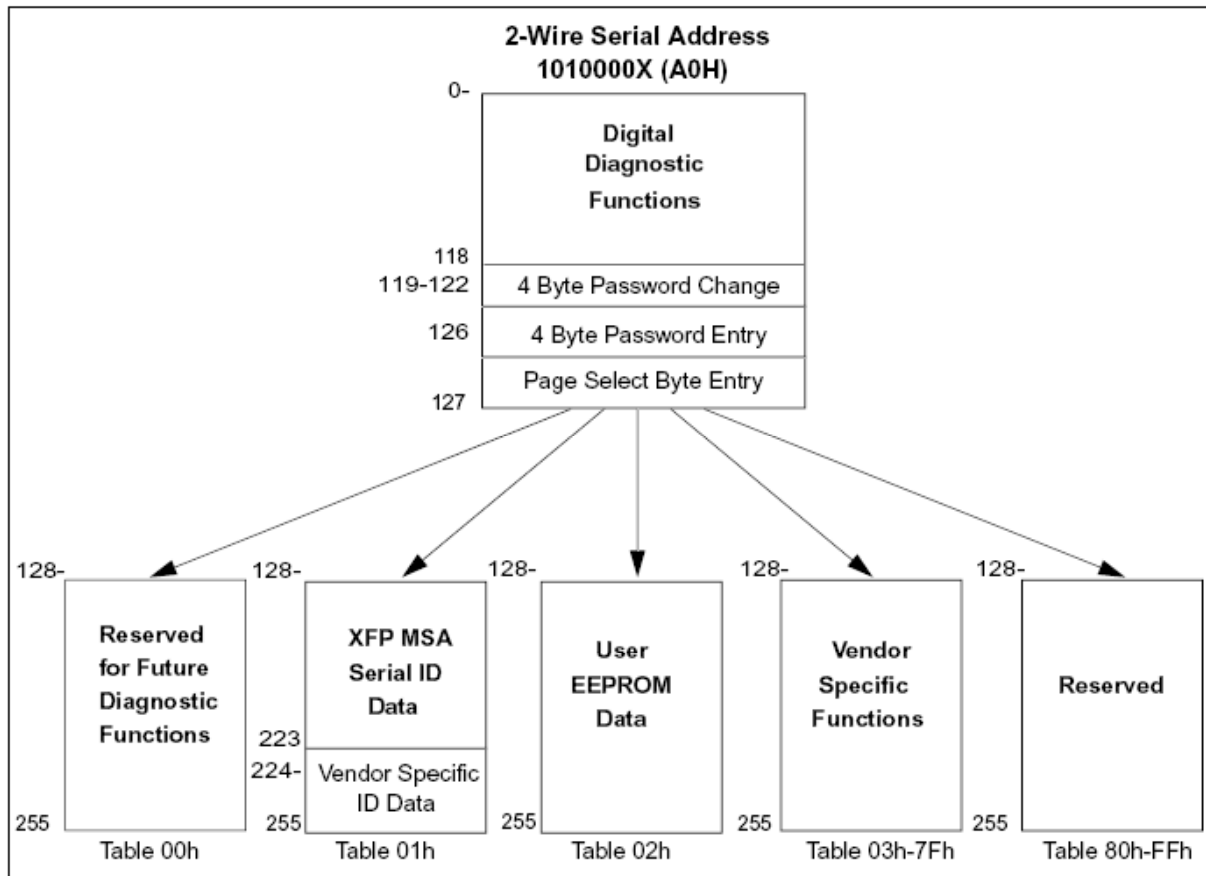



## XFP Management Interface

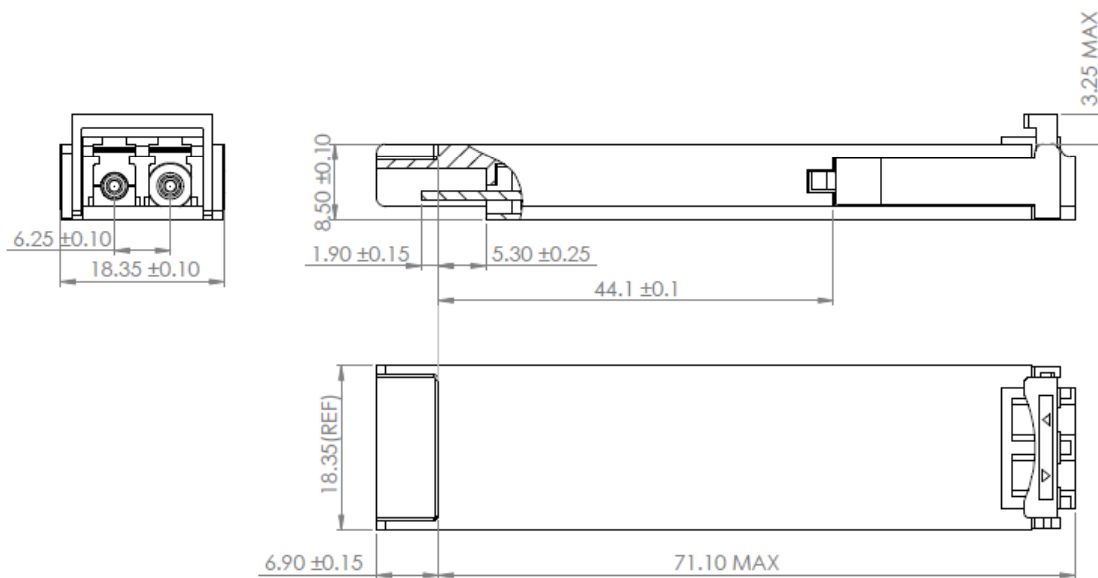

## Digital Diagnostic Monitoring Interface

Five transceiver parameter values are monitored. The following table defines the monitored parameter's accuracy.

Parameter	Range	Accuracy	Calibration
Temperature	0 to +70°C (C)	$\pm 3^\circ\text{C}$	Internal
Voltage	2.97 to 3.63V 4.73 to 5.25V	$\pm 3\%$	Internal
Bias Current	0 to 100mA	$\pm 10\%$	Internal
TX Power	0 to +4dBm	$\pm 2\text{dB}$	Internal
RX Power	-24 to -8dBm	$\pm 2\text{dB}$	Internal

## For More Information

Shenzhen Optostar Optoelectronics Co., Ltd  
 Address: A-14, Haide Building, Haide Second Road Nanshan District, Shenzhen, P.R. China  
 Tel: +86-755-26400198 +86-755-26400288  
 Fax: +86-755-26411001  
 Email: info@optostar.com.cn  
 Skype: ouyangroya  
 Web: www.optostar.com.cn